



Tel: 800.285.0666 | sales@wastequip.com
www.galbreathproducts.com

Container Handler

SLCH – MODELS

MODEL: SINGLE LOADED CONTAINER HANDLER

(**SLCH-93/113**) – Single Loaded Container Handlers are uniquely engineered to transfer heavy loads more smoothly, efficiently, and most importantly, safely. These models improve maneuverability and rear visibility by maximizing weight distribution to ensure that the containers will sit level on the chassis. By putting the center of gravity in front of the rear axles, Single Loaded Container Handlers transport both rear and front load containers securely at highway speeds.



Standard Features

- Inside joystick control
- Pintle / reese hitch-ready rear apron / bumper with LED lighting
- Ratchet retainer straps
- Rear-load attachment
- Back-up alarm
- Hoist-up alarm with signal light
- Plug-and-Play™ wiring
- Rotates to fully dump container into standard 30-yard open-top
- 20-gallon hydraulic reservoir with 3 micron return filtration
- Warranty: 1-year



3 Micron return filtration inside of tank



20-gallon steel hydraulic tank side mounted w/ dual sight/ temp gauge



Inside air controls in power tower



Rear apron & bumper assembly complete w/ LED lighting & pintle/ reese adaptable

FEATURE	SLCH-93	SLCH-93X	SLCH-113	SLCH-113X
Clear CA	93"	93"	113"	113"
Unmounted weight	4,960 lbs.	5,410 lbs.	5,100 lbs.	5,550 lbs.
Wheelbase	163" min.	163" min.	183" min.	183" min.
After frame	31 1/2"	31 1/2"	31 1/2"	31 1/2"
Adding Totar cart platform	Add 3' to CA	Add 3' to CA	Add 3' to CA	Add 3' to CA
Adding behind the cab storage	Add to CA	Add to CA	Add to CA	Add to CA
Front axle capacity	10,000 lbs.	10,000 lbs.	10,000 lbs.	10,000 lbs.
Rear axle capacity	15,000 lbs.	15,000 lbs.	15,000 lbs.	15,000 lbs.
Chassis frames	50,000 psi or more	50,000 psi or more	50,000 psi or more	50,000 psi or more
Section modulus	15.5 in ³	15.5 in ³	15.5 in ³	15.5 in ³
Dual rear wheels	Recommended	Recommended	Recommended	Recommended
Adjustable Fork Height	N/A	24"	NA	24"

Available Options

- Toolbox styles and sizes (steel, aluminum)
- PTO for automatic or manual transmissions
- Work lights
- Steel, aluminum or poly fenders
- Camera kit
- Air compressor for non-air trucks
- Factory mounting
- Lid holder and hinge rod holder
- Pintle hook and reese style hitch
- Toter cart carrier behind cab
- Auto load with remote*

*Factory mount models



Pintle hook & reese style hitch

Toolbox styles and sizes (steel, aluminum)

Fender options in steel, aluminum or poly

Rear view/backup camera systems

SLCH-93 shown - tex needed here



Container Handler

Figure 1

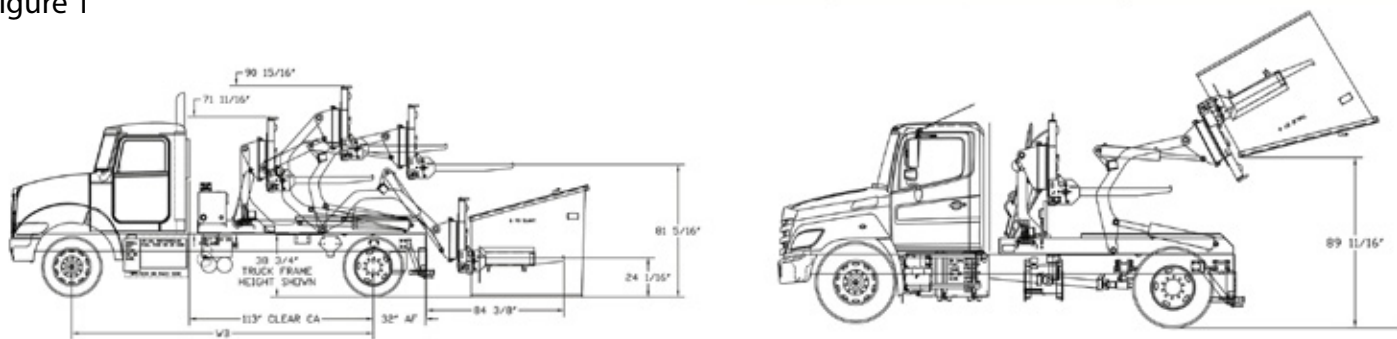

Specifications

Capacity: Up to 8,000 lbs.* see weight chart

Stacking capability: Various sizes (example: two 4-yard or two 2-yard containers)**

Capable of dumping into standard 30-yard open-top container

ANSI compliant container sizes (capacity):

Front load (FEL): 2 to 10-yards

Rear load (REL): 2 to 6-yards

* When using ANSI compliant front load or rear load containers in good working condition, not to exceed container manufacturer's load capacity rating or truck chassis center of gravity limitation. Contact Galbreath or your local Galbreath dealer for more information.

** On-road. Capable of carrying more containers for in-yard use.

***Only FEL's (front load containers) can be rotated with a maximum load of 4,000 lbs.

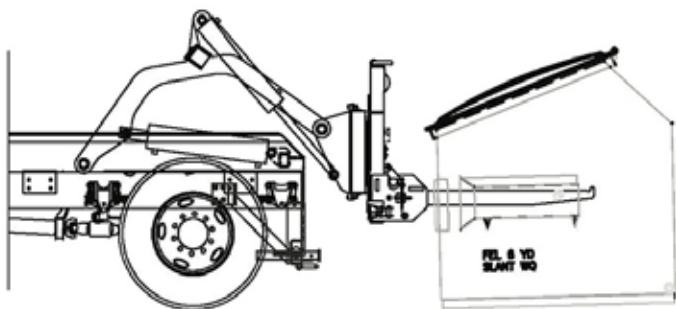

SIZE	FRONT LOAD	COG	REAR LOAD	COG
1 yard	8,000 lbs.	133"	6,000 lbs.	126"
2 yard	8,000 lbs.	138"	6,000 lbs.	135"
3 yard	7,400 lbs.	140"	6,000 lbs.	158"
4 yard	7,100 lbs.	145"	4,000 lbs.	165"
6 yard	6,700 lbs.	153"	4,000 lbs.	185"
8 yard	6,300 lbs.	161"		
10 yard	5,800 lbs.	173"		

* Only front load containers can be rotated. Minimum chassis requirement 25,000 (10,000 front and 15,000 rear). Based on ANSI compliant containers of standard construction within manufacturer's maximum load and weight rating. Based on truck with 4,910 lbs. front and 183" WB with static water level loads.

The SLCH models have been optimized for use with 25" pocket heights on FEL type ANSI compliant containers. The SLCH-X models were developed to be compatible with FEL containers that have fork pocket openings ranging from 17" up to 44.5" and REL containers with trunnion bar heights ranging from 45" up to 49".

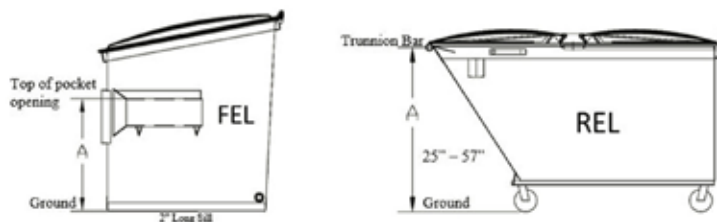

Distributed by:



Galbreath is a Wastequip brand. Wastequip is the leading North American manufacturer of waste and recycling equipment for collecting, processing and transporting recyclables and solid or liquid waste. © Wastequip 2017 All rights reserved. Specifications subject to improvement without notice. Equipment displayed should be operated by properly trained personnel. Operators should become familiar with OSHA, ANSI and any other applicable standards or laws for using this equipment. Improper use, misuse, or lack of maintenance could cause injury to people and/or property. Photos used in the literature are illustrative only. We assume no liability or responsibility for proper training/operation of equipment not manufactured by Wastequip. We reserve the right to make changes at any time without notice. Information contained within this literature is intended to be the most accurate available at time of printing.